

DEPARTMENT: Public Works

BY: Allen Toschi
PHONE: 966-5356

RECOMMENDED ACTION AND JUSTIFICATION:

Authorize Public Works to solicit Request for Proposals (RFP) for emergency repairs on Old Highway South due to storm damage and authorize the Director of Public Works to award the project and execute a Contract with the lowest responsible bidder .

This project is a result of damages associated with the rains in late December 2010, including the Old Highway. The project is 96% reimbursable from Federal Emergency Management Administration and is estimated at \$35,000.

The proposal includes all associated costs to stabilize/restore the slip on Old Highway and installation of a multi-flow drainage system approximately 465 feet long in the westerly ditch line on Old Highway.

BACKGROUND AND HISTORY OF BOARD ACTIONS:

The Board has approved like projects in the past.

ALTERNATIVES AND CONSEQUENCES OF NEGATIVE ACTION:

Financial Impact? () Yes () No	Current FY Cost: \$	Annual Recurring Cost: \$
Budgeted In Current FY? () Yes () No () Partially Funded		
Amount in Budget: \$		List Attachments, number pages consecutively
Additional Funding Needed: \$		Request for Proposals
Source:		
Internal Transfer		
Unanticipated Revenue	_____ 4/5's vote	
Transfer Between Funds	_____ 4/5's vote	
Contingency	_____ 4/5's vote	
() General () Other		

CLERK'S USE ONLY:

Res. No.: 11-34 Ord. No. _____
Vote - Ayes: 5 Noes: _____
Absent: _____
 Approved
 Minute Order Attached () No Action Necessary

COUNTY ADMINISTRATIVE OFFICER:

Requested Action Recommended
 No Opinion
Comments:

The foregoing instrument is a correct copy of the original on file in this office.

Date: _____
Attest: MARGIE WILLIAMS, Clerk of the Board
County of Mariposa, State of California

By: _____
Deputy

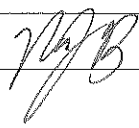
CAO: 



COUNTY of MARIPOSA

P.O. Box 784, Mariposa, CA 95338 (209) 966-3222

JIM ALLEN, CHAIR
JANET BIBBY, VICE-CHAIR
LEE STETSON
LYLE TURPIN
KEVIN CANN

DISTRICT V
DISTRICT III
DISTRICT I
DISTRICT II
DISTRICT IV



MARIPOSA COUNTY BOARD OF SUPERVISORS

MINUTE ORDER

TO: ALLEN TOSCHI, Public Works Director
FROM: MARGIE WILLIAMS, Clerk of the Board *mw*
SUBJECT: Authorize Public Works to Solicit Request for Proposals (RFP) for Emergency Repairs on Old Highway South due to Storm Damage, and Authorize the Director of Public Works to Award the Project and Sign an Agreement with the Lowest Responsible Bidder

RES. 11-34

THE BOARD OF SUPERVISORS OF MARIPOSA COUNTY, CALIFORNIA

ADOPTED THIS Order on January 25, 2011

ACTION AND VOTE:

- 5 **Public Works**
 Authorize Public Works to Solicit Request for Proposals (RFP) for Emergency Repairs on Old Highway South due to Storm Damage, and Authorize the Director of Public Works to Award the Project and Sign an Agreement with the Lowest Responsible Bidder
 BOARD ACTION: Discussion was held with Allen Toschi relative to the request, and he advised of the reimbursement status and current cost estimates. Supervisor Cann asked about the suggestion of having a local bid preference. Rick Benson advised that this can be done with purchasing, but not with Public Works projects. Discussion was held. (M)Bibby, (S)Cann, Res. 11-34 was adopted approving the recommended actions. Supervisor Cann asked that Supervisors Bibby and Allen clarify the contracting provisions with the Contractors Association when they meet this evening. Ayes: Unanimous.

Cc: Bill Davis, Auditor
File

COUNTY of MARIPOSA



Allen Toschi
Director

4639 Ben Hur Road
Mariposa, CA 95338
Phone: (209) 966-5356
Fax: (209) 966-2828

January 19, 2011

DEPARTMENT OF PUBLIC WORKS

Divisions of:

Administration	Airport
Cemeteries	County Surveyor
Design & Construction	Engineering
Facilities	Parks & Rec.
Roads	Solid Waste
Transportation	Fleet Maintenance

REQUEST FOR PROPOSAL

OLD HIGHWAY SLOPE RESTORATION & INSTALLATION OF DRAINAGE SYSTEM

Mariposa County Public Works is requesting for proposals including all associated costs to stabilize / restore the slip on Old Highway at P.M. 24.750 and Installation of a multi-flow drainage system approximately 465 feet long in the westerly ditch line on Old Highway. The pricing for Parts "A" and "B" are to be submitted separately.

This work would be done in two parts, details / scope of which are attached herewith:

PART 'A': FILL SLOPE STABILIZATION AND RESTORATION

This work consists in the installation of 18 Nos. 2' X 2' x 6' plain concrete blocks in three rows and anchored 10 ft back into the fill slope with 3/8" cable. Fill material will be placed onto the fill slope and compacted to match remainder of existing fill slope on Old Highway at P.M. 24.750. The finished slope shall be seeded and covered with rice netting on the compacted area as specified.

PART 'B': INSTALLATION OF A MULTI-FLOW DRAINAGE SYSTEM

Install approx. 265 feet of 12" multi-flow drainage tubing Southerly in the Westerly ditch line on Old Highway at P.M. 24.750, and approx. 200 feet of 18" multi-flow drainage tubing Northerly in the Westerly ditch line on Old Highway at P.M. 24.755.

Proposals are due in the Public Works Office by 3.00 p.m. on February 17, 2011.

Please submit questions (if any) and proposals to:

Mohamed Cader
Mariposa County Public Works
4639 Ben Hur Road, Mariposa, CA 95338
Phone: (209) 966 5356 x 208
E-mail: mcader@mariposacounty.org

COUNTY of MARIPOSA



Allen Toschi
Director

4639 Ben Hur Road
Mariposa, CA 95338
Phone: (209) 966-5356
Fax: (209) 966-2828

DEPARTMENT OF PUBLIC WORKS

Divisions of:

Administration	Airport
Cemeteries	County Surveyor
Design & Construction	Engineering
Facilities	Parks & Rec.
Roads	Solid Waste
Transportation	Fleet Maintenance

January 19, 2011

OLD HIGHWAY SLOPE RESTORATION & INSTALLATION OF DRAINAGE SYSTEM

PART 'A': FILL SLOPE STABILIZATION AND RESTORATION

General Work Description

This work consists in the installation of 18 Nos. 2' X 2' x 6' plain concrete blocks in three rows and anchored 10 ft back into the fill slope with 3/8" cable. Fill material will be placed onto the fill slope and compacted to match remainder of existing fill slope on Old Highway at P.M. 24.750. The finished slope shall be seeded and covered with rice netting on the compacted area as specified.

Scope of Work

1. Place 2' x 2' x 6' plain concrete blocks with top eye, seven on the first row, six on the second row and five on the third row, anchored back into the fill slope with 3/8" cable at the base of the fill slope, as per the attached drawing and as directed by the Engineer. Refer to Section 72-4 of the Caltrans Standard Specifications, May 2006 "Concrete Slope Protection, Gutter Lining, Ditch Lining and Channel Lining", sub-section 72-4.02 "Foundation Preparation"
The base course of block shall be placed on an evenly graded surface. Remainder of the fill slope is to be filled with suitable fill material and compacted to match adjacent existing fill slope (approx. 2H:1V). Back fill material (native soil) shall be placed in uniform layers and shall be brought up uniformly on all sides of the structure. The thickness of each layer of backfill shall not exceed 8" before compaction. The required relative compaction shall not be less than 95 %. Also, Refer to Section 19: Earthwork of the Caltrans Standard Specifications, May 2006.
Compacted area shall be seeded and covered with rice netting. Listed below are the specified seed varieties:

Blando Brome
Annual Ryegrass
Rose Clover*
Lana Vetch*
Zorro Annual Fescue**

*These are legumes. When purchasing seed be sure to specify that you want inoculated seed.

** California Native.

2. The top 1 foot shall be native soil and match existing finished shoulder and roadway surface.
3. Any damage from equipment to the asphalt roadway shall be repaired as directed by the engineer.

②

Traffic Control

All traffic control shall follow the guidelines in Part 6 of the California MUTCD. Traffic will be allowed to ingress and egress on Old Highway with no more than 15 minute delays. Emergency vehicles shall be allowed to ingress and egress (ambulance, sheriff, and fire) with no more than a five minute delay. The roadway shall be open and safe for traffic after temporary traffic control is removed.

PART 'B': INSTALLATION OF A MULTI-FLOW DRAINAGE SYSTEM

General Work Description

Install approx. 265' of 12" multi-flow drainage tubing Southerly in the Westerly ditch line on Old Highway at P.M. 24.750, and approx. 200' of 18" multi-flow drainage tubing Northerly in the Westerly ditch line on Old Highway at P.M. 24.755.

Scope of Work

1. Install approx. 265' of 12" multi-flow drainage tubing Southerly in the Westerly ditch line on Old Highway at P.M. 24.750. Install approx. 200' of 12" multi-flow tubing Northerly in the Westerly ditch line on Old Highway at P.M. 24.755. Each multi-flow drainage system shall have an end cap and daylight with hard line into a culvert basin. All multi-flow drainage tubing shall be a sand based installation. The exact locations will be referenced in the field. Refer to Section 68: Subsurface Drains of the Caltrans Standard Specifications, May 2006.
2. After installation is completed the ditch line is to be reshaped for surface drainage.
3. Any damage from equipment to the asphalt roadway shall be repaired as directed by the engineer.

Traffic Control

All traffic control shall follow the guidelines in Part 6 of the California MUTCD. Traffic will be allowed to ingress and egress on Old Highway with no more than 15 minute delays. Emergency vehicles shall be allowed to ingress and egress (ambulance, sheriff, and fire) with no more than a five minute delay. The roadway shall be open and safe for traffic after temporary traffic control is removed.

OLD HIGHWAY STORM DAMAGE P.M. 24.750

EL. 1908.42	1/2" multi flow drainage tubing	263.278	2001.121 (2001.04)	EL. 1907.60
	1/2" multi flow drainage tubing	201.431		

Old Highway

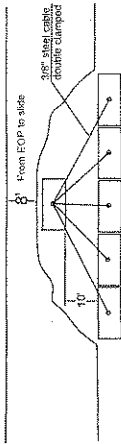

PLAN

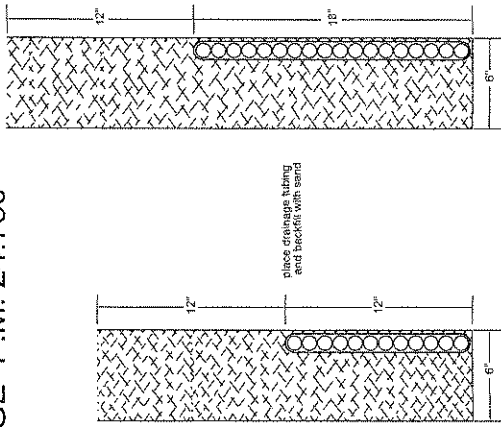

TRENCH DETAIL

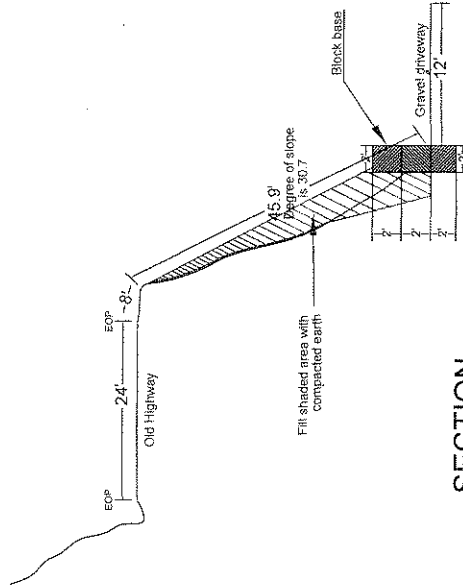

SECTION

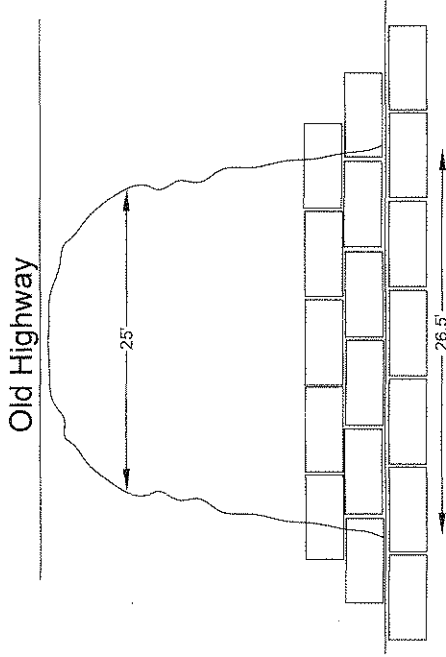

ELEVATION

④