

DEPARTMENT: Public Works

By: Michael D. Edwards

Phone: 966-5356

Director of Public Works

RECOMMENDED ACTION AND JUSTIFICATION: (Policy Item: Yes___ No X)

Approve the proposed reorganization of the Facilities Maintenance Division and the transfer of the necessary funding between budgets. The following actions are recommended:

1. Do not reallocate the position of the Parks Maintenance Supervisor who is retiring effective December 7, 1994. This is consistent with the Board's action taken during FY 94/95 budget hearings to delete any positions that have been vacated.
2. Authorize the allocation of two new positions within Facilities Maintenance. The positions would be a Maintenance Worker I and Custodian. Public Works has recently recruited for both classifications.
3. Transfer the necessary funding of \$2,439 (one-half of year's cost) from Roads to Facilities per the attached Budget Action form.

These actions would provide two new positions which are currently needed within this division. With this action, Public Works will terminate the outside custodial services at the Road Division offices with a 30-day notice. As shown on Attachment #2, this would provide a net annual General Fund savings of \$2,023. Attachment #3 shows the current organizational structure prior to the retirement of the Parks Maintenance and Building Maintenance Supervisors. Attachment #4 shows the proposed organizational structure with no resulting net increase in personnel.

BACKGROUND AND HISTORY OF BOARD ACTIONS:

During the budget hearings, Public Works requested additional funding for a full-time custodial position. This request was denied. Also during budget hearings, the Board took action to eliminate the Building Maintenance Supervisor position through the offer of a "golden handshake" retirement. That action saved approximately \$43,200 in General Fund costs. That cost savings is not included in this proposed action.

The Board also took action during the budget that all positions that are vacated this fiscal year be deleted with an option to recreate them if justified by the department head with Board concurrence.

LIST ALTERNATIVES AND CONSEQUENCES OF NEGATIVE ACTION:

1. Do not approve this reorganization and delete the Parks Maintenance Supervisor position upon the incumbent's retirement. This would save an additional \$42,634 in annual costs but would severely hamper the ability of the Facilities Maintenance Division to perform its' duties.
2. Recreate the Parks Maintenance Supervisor position and authorize Public Works to begin a recruitment. This would have no net long-term effect compared to the current situation. This would

have a short-term impact on the division requiring recruitment and training of a qualified individual.

- 3. Approve a reorganization that would combine the Parks Maintenance Supervisor and Building Maintenance Supervisor into one position overseeing two crews. This would have a slight net cost impact. It would take some supervisorial burden away from the Facilities Maintenance Manager, but would not appreciably enhance the level of service over the current situation.

COSTS: (<input type="checkbox"/> Not Applicable)		SPECIAL INSTRUCTIONS: List the attachments and number the pages consecutively: <u>1. Budget Action Form</u> <u>2. Cost Analysis</u> <u>3. Current Organizational Chart</u> <u>4. Proposed Organizational Chart</u> _____ _____
A. Budgeted current FY	\$ 42,634	
B. Total anticipated costs	\$ 2,439 *	
C. Required additional funding	\$ _____	
D. Internal transfers	\$ _____	
SOURCE: (<input type="checkbox"/> 4/5th Vote Required)		
A. Unanticipated revenues	\$ _____	
B. Reserve for contingencies	\$ _____	
C. Source description: * <u>TRANSFER FROM ROADS BUDGET</u>		
Balance in Reserve Contingencies, if approved: \$ _____		

CLERK'S USE ONLY Res. No.: <u>94-503</u> Ord. No. _____ Vote - Ayes: <u>4</u> Noes: _____ Absent: <u>_____</u> Abstained: _____ <input type="checkbox"/> Approved (<input type="checkbox"/> Denied) <input checked="" type="checkbox"/> Minute Order Attached (<input type="checkbox"/> No Action Necessary)		ADMINISTRATIVE OFFICER'S RECOMMENDATION: This item on agenda as: <input checked="" type="checkbox"/> Recommended <input type="checkbox"/> Not Recommended <input type="checkbox"/> For Policy Determination <input type="checkbox"/> Submitted with Comment <input type="checkbox"/> Returned for Further Action Comment: _____ A.O. Initials: <u>mc / by hws</u>
The foregoing instrument is a correct copy of the original on file in this office. Date: _____ ATTEST: <u>MARGIE WILLIAMS, Clerk of the Board</u> County of Mariposa, State of California By: _____ Deputy		

MARIPOSA COUNTY BOARD OF SUPERVISORS

MINUTE ORDER

TO: MIKE EDWARDS, Public Works Director
FROM: MARGIE WILLIAMS, Clerk of the Board *By: J.B.*
SUBJECT: Proposed Reorganization of the Facilities
Maintenance Division and Transfer Funding
Resolution Number 94-503

THE BOARD OF SUPERVISORS OF MARIPOSA COUNTY, CALIFORNIA,
ADOPTED THIS Order on November 22, 1994

ACTION AND VOTE:

10:15 a.m. Mike Edwards, Public Works Director;
C) Resolution Approving Proposed Reorganization of the
Facilities Maintenance Division and Transfer the Necessary
Funding Between Budgets
BOARD ACTION: (M)Parker, (S)Balmain, Res. 94-503 adopted.
Supervisor Taber was excused at 10:56 a.m. for the rest of
the meeting. Following further discussion, motion was
amended, agreeable with maker and second, to provide
direction to staff to review whether the Golden Handshake
could be offered to the retiring Park Maintenance
Supervisor/Ayes: Baggett, Balmain, Erickson, Parker;
Excused: Taber.

cc: Ken Hawkins, Auditor
Nancy Kyle, Personnel Analyst
Jeffrey G. Green, County Counsel
File

**COUNTY OF
MARIPOSA**

BUDGET ACTION FORM

DEPT/DIV: Public Works

CONTACT: Michael D. Edwards

DATE: November 15, 1994

PHONE: 966-5356

ACTION REQUESTED: (Check All That Apply)

- Budget appropriation by Board of Supervisors (4/5ths Vote Required): Amending the total amount available in the County Budget, or in any one fund of the budget, or appropriating Reserve for Contingencies;
- Transfer by Board of Supervisors (3/5ths Vote Required): Moving existing appropriation from one budget to another, or between categories within a budget unit;
- Transfer by Administrator: Moving existing appropriations within a single budget category between line items (i.e. services and supplies, etc.);
- Transfer by Auditor: Moving salaries between line items to accomodate variances internal to salaries; OR transfers within the County budget under \$50.00 to accomodate minor variations from the budget.

<u>FUND/DEPT/ACCT NO.</u>	<u>LINE ITEM DESCRIPTION</u>	<u>AMOUNT (FROM)/TO</u>
002-0301-581-0409	Road Dept. Janitorial	(2,439.00)
001-0128-473-0198	Facilities Maint. Custodial	2,439.00

Justification: See attached Board item.

Department Head Signature: *Michael D. Edwards* Date: 11/15/94
 Approved By: Res. No. 94-503 Clerk: mw Date: 11-22-94
 Administrator: _____ Date: _____
 Auditor: _____ Date: _____

AUDITOR'S USE ONLY:

Description: _____ Transfer No.: _____
 _____ B.R. No.: _____

COST ANALYSIS

PROPOSED FACILITIES MAINTENANCE REORGANIZATION

<u>CLASSIFICATION</u>	<u>RANGE</u>	<u>STEP</u>	<u>MONTHLY SALARY</u>	<u>HOURLY WAGE</u>	<u>BENEFITS 40.3%</u>	<u>TOTAL ANNUAL SALARY</u>
Parks Maint. Superv. (Delete)	147	5 + 6%	2,532.34	14.5369	1,020.53	42,634
Maint. Worker I (Add)	93	1	1,502.00	8.6658	605.31	(25,288)
Custodian (Add)	67	1	1,320.00	7.6158	531.96	(22,223)
ANNUAL NET COST TO FACILITIES MAINTENANCE (4,877)						
ANNUAL SAVINGS FROM ELIMINATION OF ROADS DIVISION CUSTODIAL SERVICE <u>6,900</u>						
NET ANNUAL SAVINGS * <u>2,023</u>						

* ASSUMES AN ANNUAL REDUCTION OF \$6,900 IN GENERAL FUND CONTRIBUTION TO THE ROAD FUND AND AN ANNUAL INCREASE OF \$4,877 TO THE FACILITIES MAINTENANCE BUDGET

CURRENT

Mariposa County Public Works Department Organizational Chart

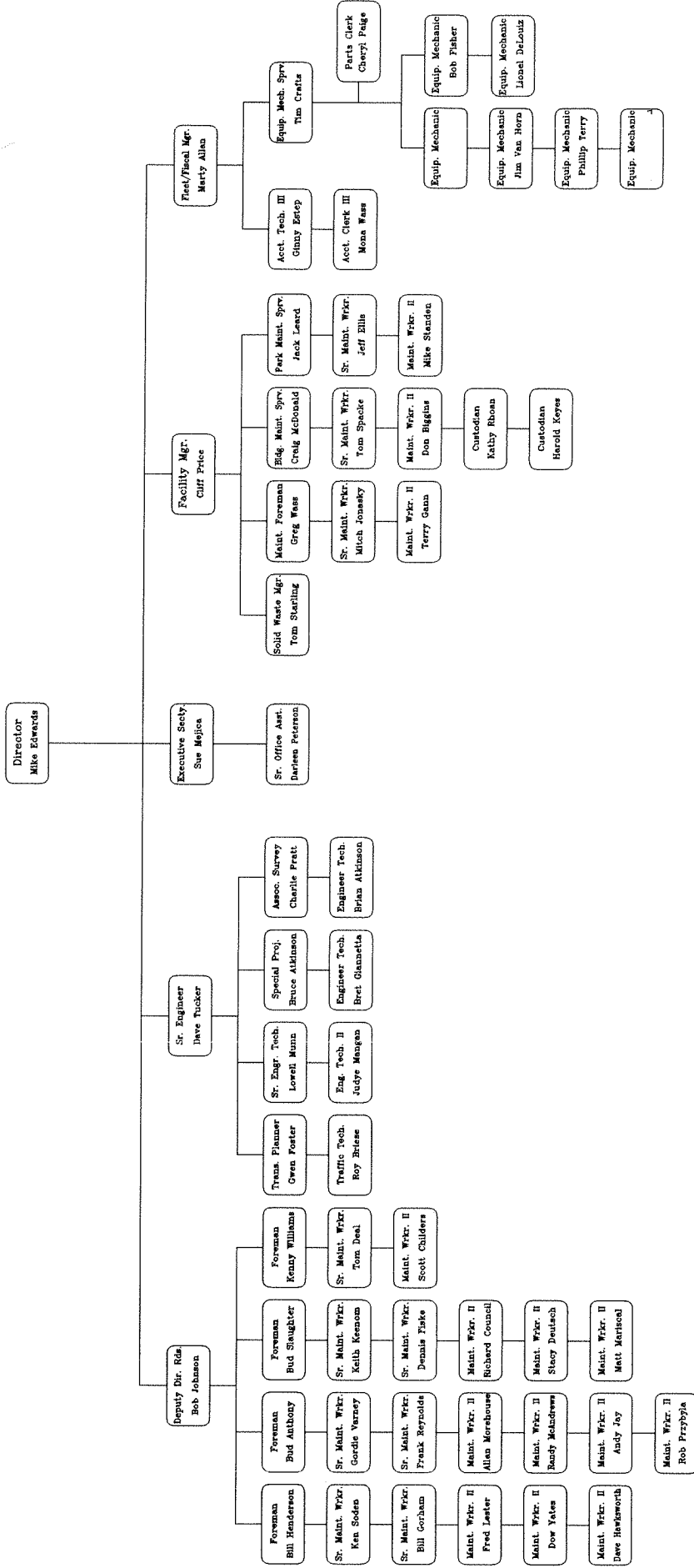

West Area East Area North Area Construction/Sig Trans/Traffic Engng/Survey Administration Solid Waste Special Dist Grade/Blgd. Maint Perk Maint Fiscal Heavy Equip/Fire Light Vehicles
 ROAD DIVISION ENGINEERING/SURVEY DIVISION FACILITIES FISCAL/FLEET

November 15, 1994

PROPOSED

Mariposa County Public Works Department Organizational Chart

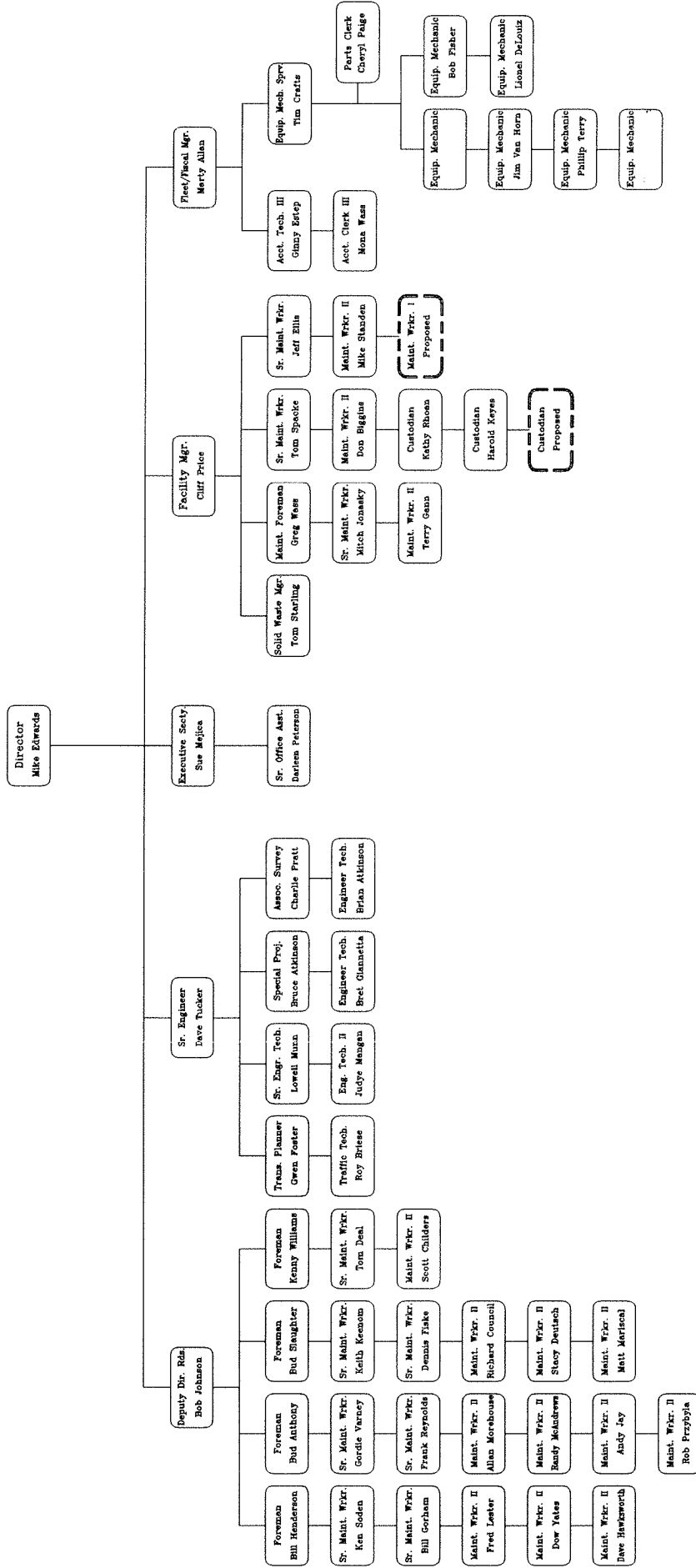

ROAD DIVISION NORTH AREA CONSTRUCTION/SIGN DIVISION ENGINEERING/SURVEY DIVISION ADMINISTRATION FACILITIES FISCAL/FLEET

November 15, 1994

ATTACHMENT # 4